

## GT6

Its rugged, lightweight aluminum design offers unmatched performance in even the most challenging conditions.



### SPECIFICATIONS

Max. torque	8,000 ft-lb (10,846.45 Nm)
Max. rotation speed	725 rpm
Push and pull capacity (standard mast)	26,000 lb (11,793 kg)
Control panel with adjustable height	20 in (508 mm) hydraulically
Head sliding clearance	16 in (406 mm)
Front-rear slide mast	10 in (254 mm)
Left-right slide mast	6 in (152 mm)
NWL diamond core drilling capacity	656 ft (200 m)*
Drill weight on CAT 308 tracks	19,250 lb (8,731 kg)

### FEATURES AND BENEFITS

- Best-in-class torque - Max. speed combo
- Reliable and simple components for affordable maintenance and continued operations under all conditions
- Weight may vary depending on options\*
- Coring capacity varies with winch type\*

**STRONGER AND STRONGER**

### Power unit (other options available on request)

Diesel engine (standard)	Cat C3.6 Tier 4 Stage 5
Horsepower	134 hp (100 kW) @ 2,400 rpm
Operation angle	45 to 90 degrees

### Hydraulic system

Hydraulic pump (2) (max. L/min - gal/min) (max. psi - bar)	191 L/min (42 US gal/min) @ 2,400 rpm (4,500 psi [310 bar]) 91 L/min (20 US gal./min) @ 2,400 rpm (3,500 psi [241 bar])
Variable volume hydraulic oil tank	1300 cc
Oil heat exchanger	Air cooling
Filtration	10 micron filter on return line
Control panel (adjustable height)	20 in (508 mm) hydraulically
Leveling jacks (4)	36 in (914 mm) stroke

### Rotary head

Final drive	HV 60-4 chain in an oil bath
Hydraulic motor	160 cc variable
Transmission	HI-LO 2-speed mechanic
Rotary head ratio	4.83:1
Lubrication	Pump-pressurized with filter

### 2-Speed transmission

Speed	Ratio	RPM	Maximum Torque
LO	3.46:1	0-210	8,000 ft-lb (10,846.45 Nm) @ 48 rpm
HI	1:1	0-725	460 ft-lb (623 Nm) @ 725 rpm

Speed and torque based on a 160 cc variable hydraulic motor at 4,500 psi (310 bar)

### Feed mast short (Feed mast with 11 ft of stroke is available)

Head stroke	78 in (1.98 m) telescopic cylinder
Dump mast	36 in (914 mm) hydraulically
Head sliding clearance	16 in (406 mm) Hydraulically
Push and pull speed	0-130 ft/min (0-40 m/min) @ 4,000 psi
Push and pull capacity	26,000 lb (12,700 kg) @ 4,000 psi
Possible angle	45 to 90 degrees
Front-rear slide mast	10 in (254 mm) displacement
Left-right slide mast	6 in (152 mm) displacement

### \* Rod clamp

Holding capacity	25,000 lb (11,340 kg)
Diameter capacity max.	5.5 in (140 mm)

### \* Main hoist

Capacity	9,000 lb (4,082 kg)
Cable diameter	1/2 in (12.7 mm)
Cable capacity	100 ft (30 m)

### \* Auxiliary hoist (fast hoist available)

Capacity	3,000 lb (1,360 kg)
Cable diameter	3/8 in (9.52 mm)
Cable capacity	100 ft (30 m)

### \* Traction hoist (synchronized with tracks)

Capacity	20,000 lb (8,164 kg)
Cable diameter	9/16 in (14.28 mm)
Cable capacity	100 ft (30 m)

### ALSO AVAILABLE (\* OPTIONS)

- Hydraulically operated SPT automatic hammer 140 lb (63.5 kg) or 340 lb (154 kg)
- Hydraulic breakout wrench
- Water pump type: Triplex, Progressive cavity and / or peristaltic
- Rod rack option
- MST 600 track or CAT308 track carriers
- Truck mounted GT6 available, with PTO or Deck Engine.

# DIMENSIONS (FOR REFERENCE ONLY, OTHER OPTIONS AVAILABLE)

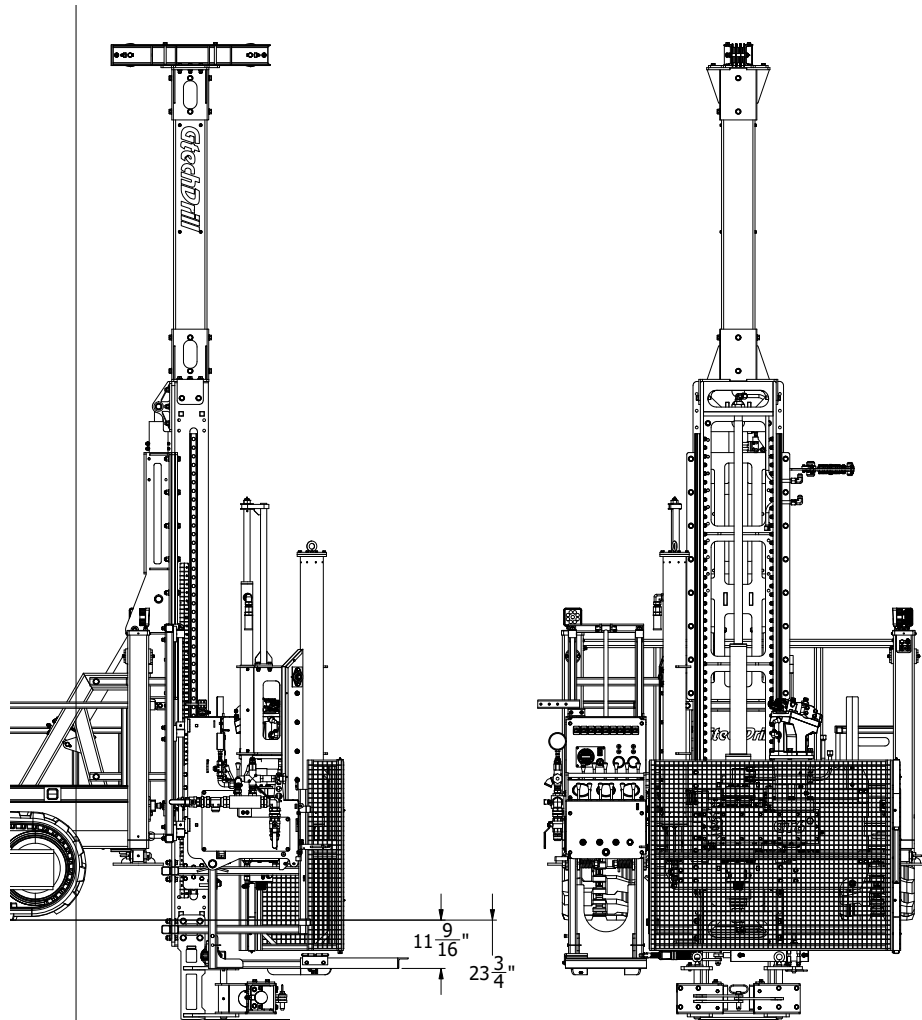
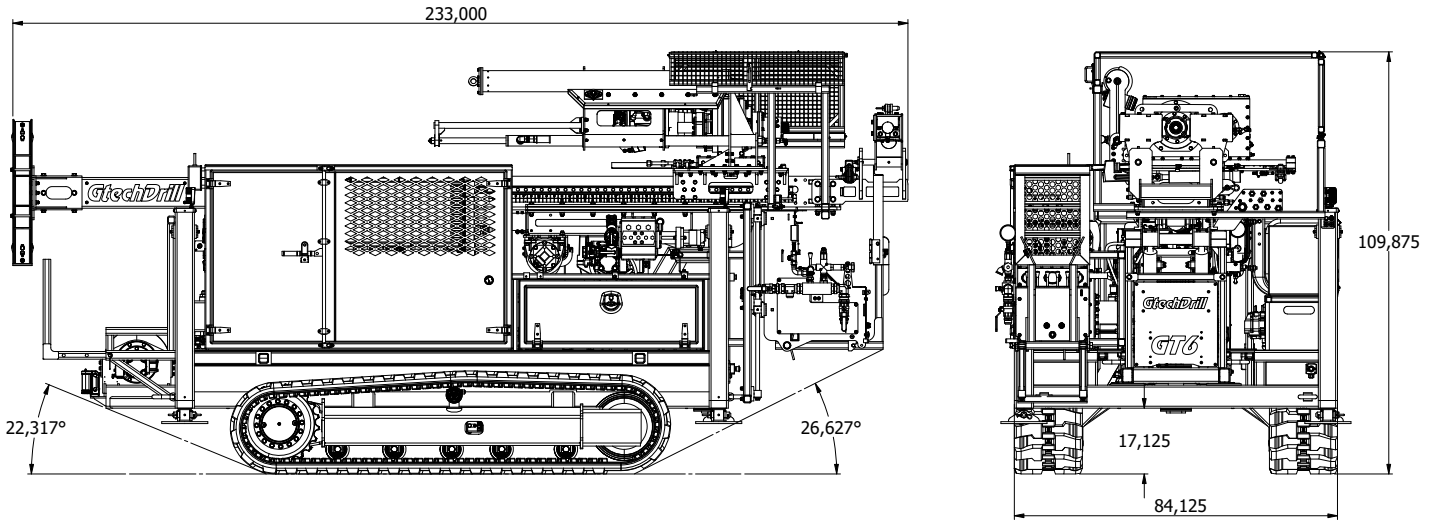

**STRONGER AND STRONGER**



+ 1 819 762 9645

110 Jacques-Bibeau St., Rouyn-Noranda, QC J9Y 0A3, Canada

[info@mbiglobal.ca](mailto:info@mbiglobal.ca) • [www.mbiglobal.ca](http://www.mbiglobal.ca)