

KmN1.4s

One of the markets most powerful
and versatile surface drills

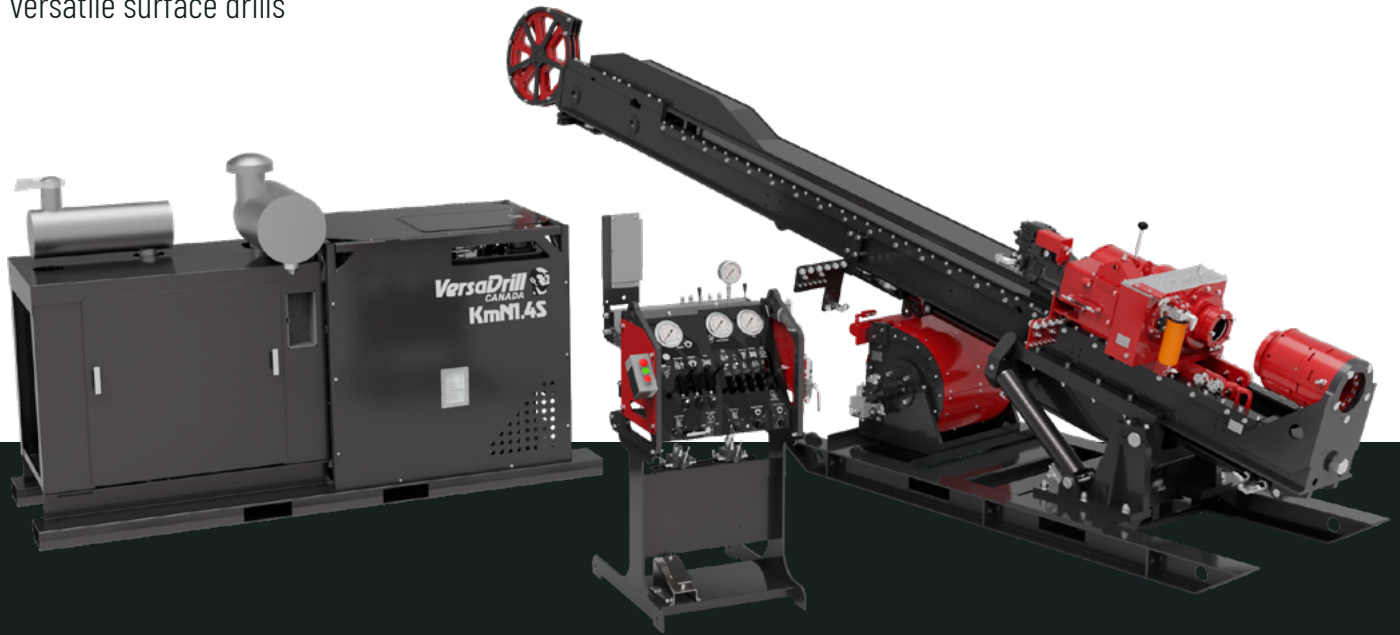

SPECIFICATIONS

Rotary head and chuck	
Holding capacity	38 000 lb (17 236 kg)
Spindle interior dimension	4.9" (124 mm) PWL Rod
Chuck operation	Spring closed and hydraulically opened
Final drive	HV 80-3 chain in an oil bath
Hydraulic Motor	160 cc variable
Transmission	HI-LO 2-speed mechanic
Rotary Head Ratio	1:2.33
Lubrication	Pump pressurized, filter and cooler
Speed	0 to 1 250 RPM

FEATURES AND BENEFITS

- Surface version (also available in underground version)
- Made of steel
- Depth capacity:
1 400 m (4 600 ft) N size
- Total weight:
17 011 lb (7 719 kg)

kmN1.4s

SURFACE DRILL

Filtration

10 micron absolute filter on return line (2)
High pressure filter (2)
One strainer inside the hydraulic tank connected to the suction (2)

Hydraulic module

Floating rotary head - Torque limit on rotary head	
Hydraulic pumps (2)	246 l/min (65 US gal/min) @ 1 800 RPM (max. 4 000 psi (275 bar)) 136 l/min (36 US gal/min) @ 1 800 RPM (max. 4 000 psi (275 bar))
System drive	Open loop, Load-sensing circuit
Hydraulic pressurized tank	55 US gal (208 l)
Oil heat exchanger	Water cooling (Air cooler optional)

Weight

Diesel power unit	1 686 lb (766 kg)
Hydraulic pump and tank	2 634 lb (1 195 kg)
Control panel	672 lb (305 kg)
Drill head	954 lb (433 kg)
Drill head hydraulic motor	70 lb (32 kg)
Drill head transmission	85 lb (39 kg)
Rod holder	452 lb (205 kg)
Feed frame assy	8 883 lb (4 029 kg)
Wireline	575 lb (261 kg)
Hydraulic hoses	1 000 lb (454 kg)
Surface mast	1 541 lb (699 kg)
Wireline	575 lb (261 kg)

Drilling capacity

*Recommended size for maximum performance	*B 2 3/16" (55,6 mm)	6 230 ft (1 900 m)
	*N 2 3/4" (69,9 mm)	4 600 ft (1 400 m)
	*H 3 1/2" (88,9 mm)	2 625 ft (800 m)
	P 4 5/8" (117,5 mm)	1 610 ft (500 m)

Drilling capacity is calculated on a 90 degree down hole and will depend on in-hole tools, ground conditions, drilling techniques and equipment used.

Drilling capacity

Recommended diesel engine: 205 HP (152 Kw) at 2 100 RPM

Feed frame

Head stroke	11 ft (3,35 m)
Raising speed	125 ft/min (38 m/min)
Lowering speed	255 ft/min (77 m/min)
Pull capacity	38 000 lb (17 336 kg) @ 4 000 psi
Push capacity	19 000 lb (8 618 kg) @ 4 000 psi
Possible angle (Surface version)	-8 to -90 degrees

Surface mast

Pull speed	240 ft/min (73 m/min)
Speed of descent	380 ft/min (115 m/min)
Single line pull capacity	12 500 lb (5 670 kg) @ 4 500 psi
Rod pull length	20 ft (6 m)

2-Speed transmission

Speed	Ratio	RPM	Maximum Torque
LO	3.46:1	0-361	4 196 lb*ft (5 689 N*m) @ 361 RPM
HI	1:1	0-1 250	1 213 lb*ft (1 644 N*m) @ 1 250 RPM

Speed and torque based on a 160 cc hydraulic motor at 4 000 psi (275 bar)

Wireline hoist

Cable capacity (3/16 in - 4.8 mm)	6 890 ft (2 100 m)
Empty Pull capacity	2 000 lb (907 kg)
Full Pull capacity	650 lb (295 kg)
Variable speed as needed	

DIMENSIONS

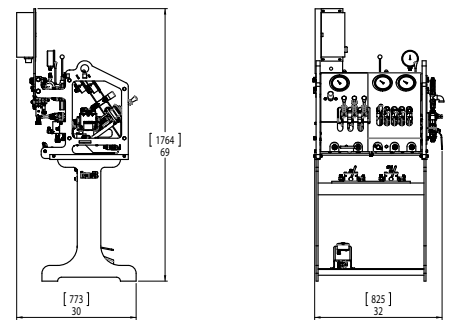
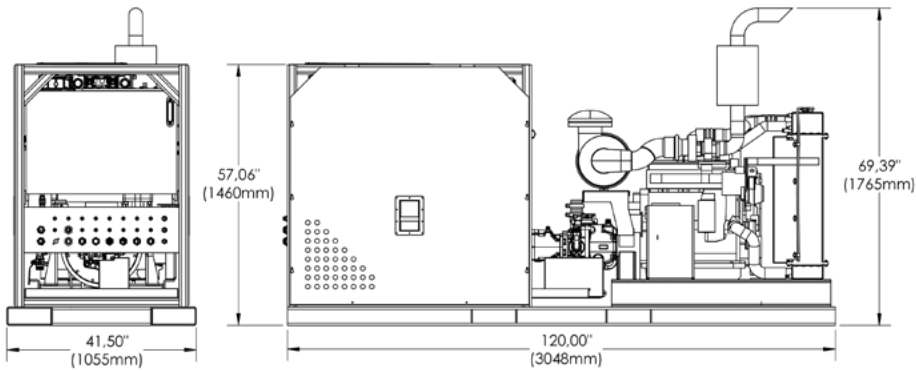
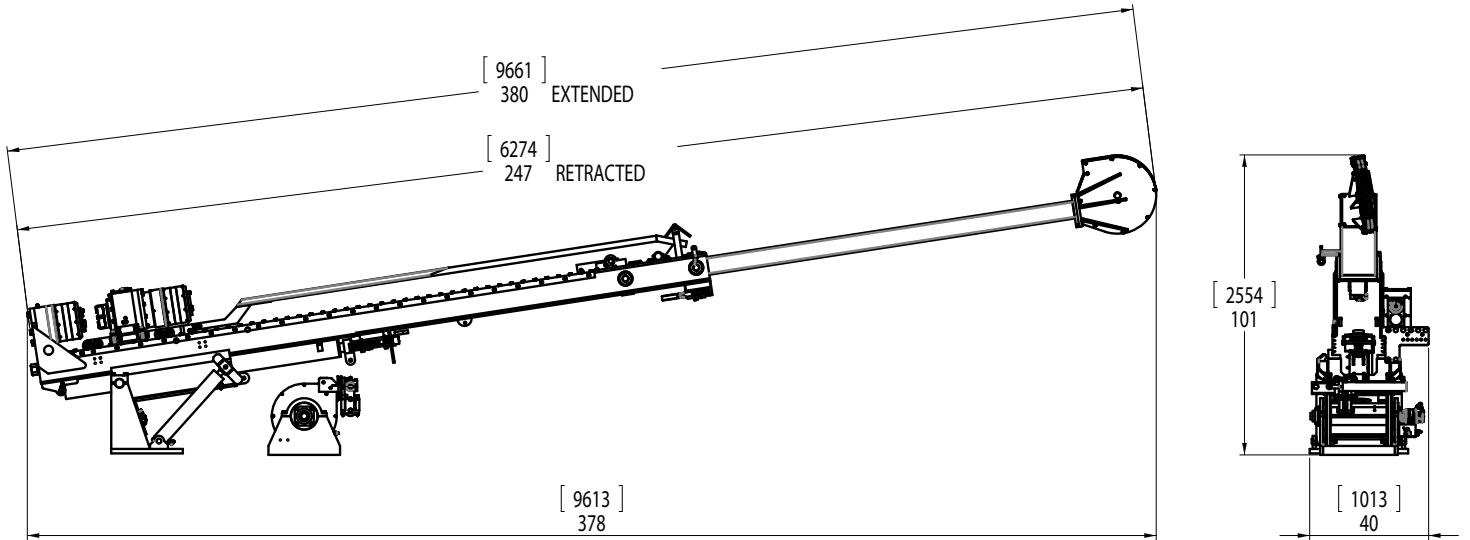

STRONGER AND STRONGER



+ 1 819 762 9645

110 Jacques-Bibeau St., Rouyn-Noranda, QC J9Y 0A3, Canada

info@mbiglobal.ca • www.mbiglobal.ca